

NOTES:

A.) ELECTRICAL SPECS:

- 1.) VOLTAGE RATING / 500 VRMS.
- 2.) IMPEDANCE / 50 OHMS.
- 3.) DIELECTRIC WITHSTANDING VOLTAGE / 1,500 VRMS.
- 4.) FREQUENCY RANGE / DC TO 4 GHz.
- 5.) INSULATION RESISTANCE / 5,000 MEGOHMS MIN.

B.) TEMPERATURE RANGE / -65° TO +165°C

C.) MATERIAL:

- 1.) BODY / 360 BRASS PER QQ-B-626.
- 2.) CONTACT / BERYLLIUM COPPER PER QQ-C-530.
- 3.) INSULATOR / TEFLON PER ASTM-D1457.

D.) FINISH:

- 1.) BODY / .0002 MIN. BRIGHT NICKEL PER QQ-N-290.
- 2.) CONTACT / .00005 MIN GOLD OVER NICKEL PER MIL-C-45204.

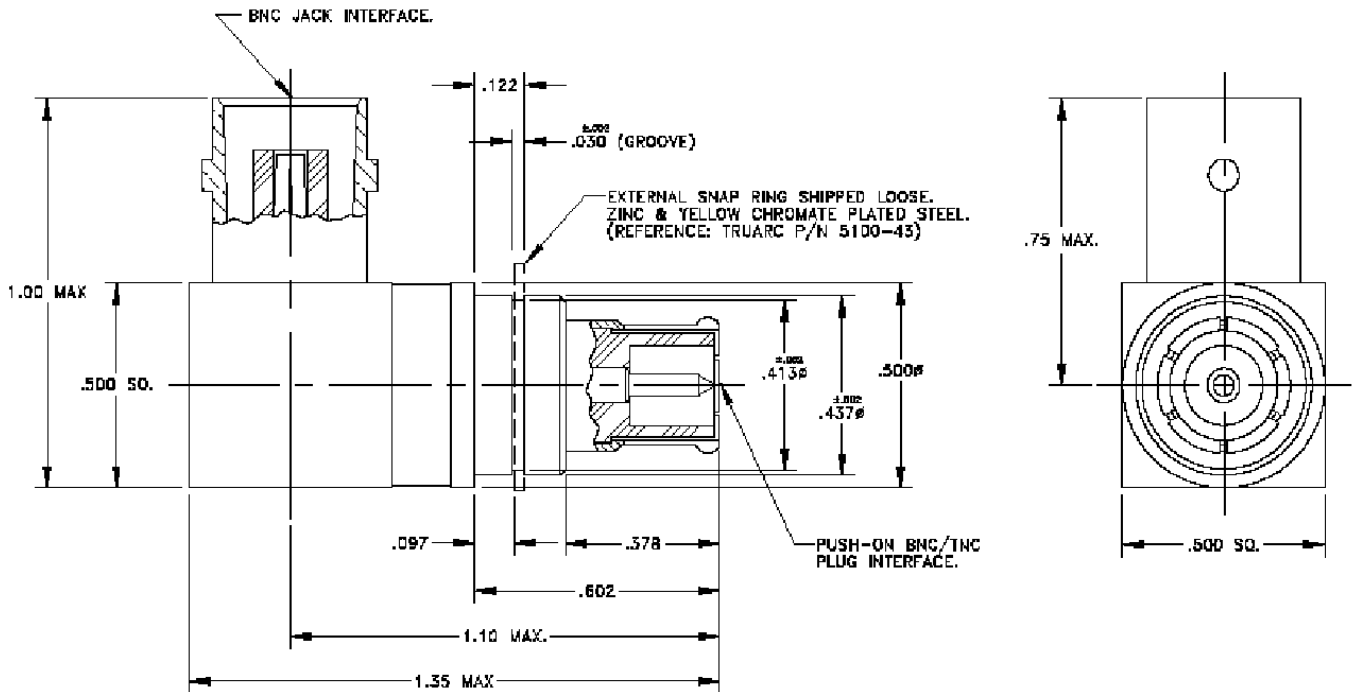

CONFIDENTIAL AND PROPRIETARY TO DEKLIN TECHNOLOGIES INC

DATE	Jan 14, 2008	 Deklin Technologies 413 CHESTERFIELD LANE NORTH AURORA, IL 60542 TEL: 630-844-1760 www.deklintech.com			
DRAWN	JAD				
CHECKED	JAD				
APPROVED	TJD				
PART NO.	DBA-600	TITLE Between Series Adaptor, Right Angle BNC to Push-On TNC/TNC Plug			
FILE		SIZE	REV. 1.0	SHEET 1/1	
		DWG TYPE	Outline	DWG NO.	20080114